

B-B) DUMBWAITER SHAFT

A-A) WALL SUPPORT

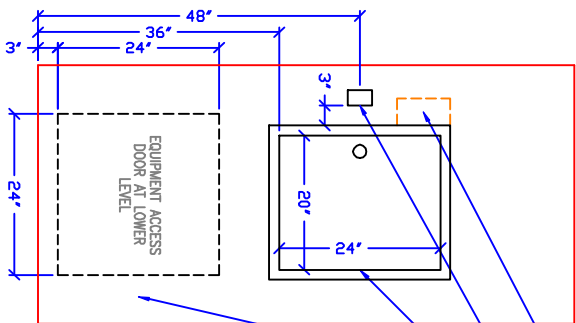

- 4W x 2TD - DOOR LOCK ROLLER POCKET FROM TOP OF DOOR FRAME DOWN 8"
- CALL/SEND BUTTON - BLOCKOUT
- 2 1/4W x 3 1/2H x 3TD
- HOISTWAY DOOR BY OTHERS W/CLOSING DEVICE OR MAGNETIC LATCH
- LEAVE FRONT WALL OPEN AT BOTTOM LANDING UNTIL EQUIPMENT IS INSTALLED

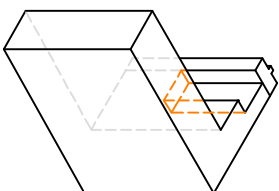

DOOR ELEVATION

**DOOR ROLLER POCKET
<ISOMETRIC VIEWS**

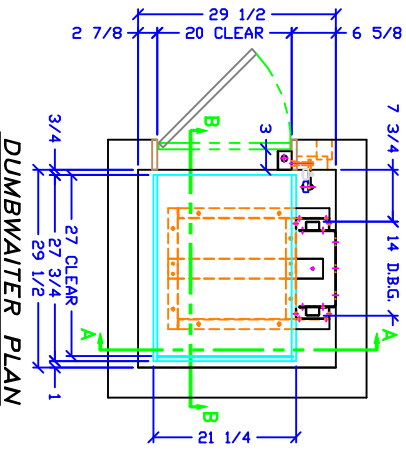

DUMBWAITER PLAN

MODEL	DB-2	# CAR OPENINGS	1
SPEED	15 FPM	DOOR LOCK	CALL
TRAVEL	2	CAB COLOR	WHI
# OF LANDINGS	2	TRACH WIDTH	28 1/2
SERVICE	RESIDENTIAL	TRACH DEPTH	28 1/2
CAPACITY	200#	MACHINE LOCATION	BELOW
OPERATION	CALL/SEND		

ELEVATOR CONCEPTS LTD.

JOB NAME:	STANDARD DUMBWAITER SINGLE OPENING
ADDRESS:	-
CITY:	-
ARCHITECT:	-
CONTRACTOR:	-
CUSTOMER:	-
REVISIONS:	-
DR. BY: DJB	DATE: 05/04/01 DWG. DW_S01